



### Go everywhere...

- High precision driving & smoothness
- Quick machine
- Comfort & agility
- Indoor / outdoor rated (Versatile)
- Easy access to the platform
- Smart transportability & lifting

### ... With the best value for money

- Robust machine
- Smart mast system
- Minimal maintenance & downtime
- Direct electric drive with brushless AC motors
- Easy access to components
- Haulotte Activ'Screen (onboard diagnostic)



### TECHNICAL DATA

### STAR 6

|                                |                   |
|--------------------------------|-------------------|
| Working height                 | 5.8 m             |
| Platform height                | 3.8 m             |
| Lift capacity                  | 230 kg            |
| Platform size                  | 0.77 x 1.38 m     |
| <b>A</b> Length                | 1.4 m             |
| <b>B</b> Width                 | 0.79 m            |
| <b>C</b> Height - stowed       | 1.75 m            |
| <b>D</b> Wheelbase             | 1.06 m            |
| <b>E</b> Ground clearance      | 6 cm              |
| Drive speed proportional       | 0.8 - 4.5 km/h    |
| Turning radius - outside       | 1.7 m             |
| Tilt alarm                     | 1.5 ° / 3 °       |
| Gradeability                   | 25 %              |
| Driveable at full height up to | 3.8 m             |
| Hydraulic system capacity      | 5 l               |
| Tires - non marking            | 308 x 108         |
| Power source                   | 12V - 105 Ah (C5) |
| Weight                         | 835 kg            |

### STANDARD EQUIPMENT

- 24 V electric drive brushless AC motors
- 12 V - 105 Ah traction batteries
- 20 A battery charger
- Battery charge indicator
- Haulotte ACTIV'Screen
- Fork lifting eyes
- Hoisting and lifting eyes
- Swing door entry gate
- Mobile potholes
- 2 drive speed
- 2 front steering wheels
- 2 rear driving wheels
- Non marking tires
- Brake release
- Hourmeter
- Horn
- Travel alarm
- Emergency stop
- Emergency hand pump
- 2 control stations at cage and ground level
- Mobile upper control box
- 2 towing hooks
- Walkable protection plinth

### OPTIONS AND ACCESSORIES

- Platform extension deck +0.4 m
- Flashing light
- Power line in platform
- Ground-fault circuit interrupter 30 mA
- Hydraulic oil for cold countries
- Biodegradable oil
- Upper control box protection cover
- Fluorescent tube caddy
- Tool tray
- Maintenance-free batteries

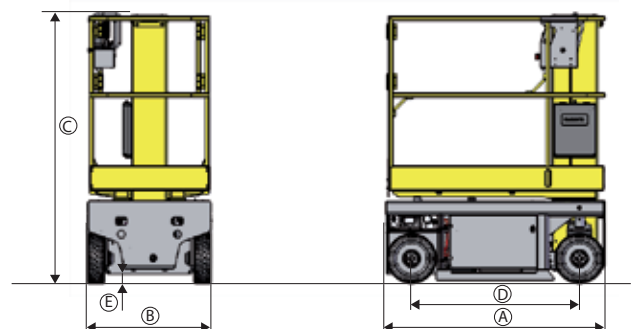
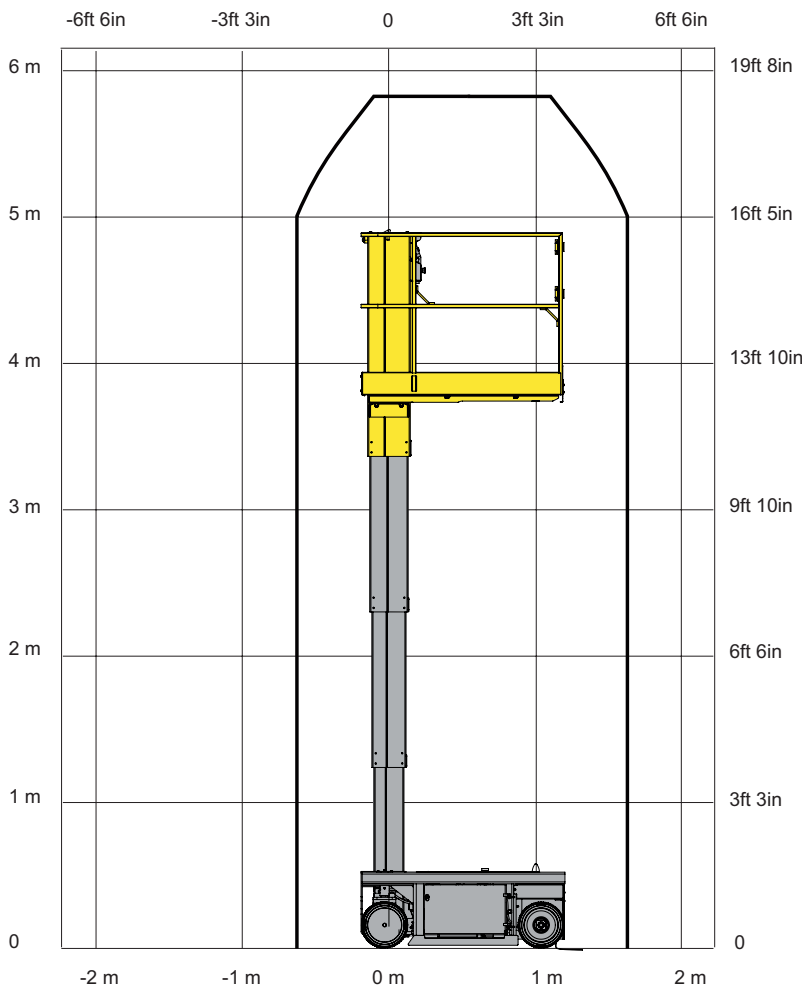

Non contractual document - We reserve the right to modify the technical characteristics of this document without notice - 10/2016