



## Performance & Ease of use

- Industry leading working envelope with an outreach of 8.3 m / 27 ft 3 in
- Best lifting speed of 40 sec
- Fully proportional and simultaneous movements
- 4-wheel steer and 360° continuous rotation for a greater productivity

## Excellent Robustness

- Rugged hoods with ergonomic handle
- Long lasting structural design

## Easy Maintenance

- Fully modular basket with upper control box cover
- Easy access to all components
- Self-diagnosis tool on lower control box

## Best Comfort and Safety Feeling

- Safe driving



**Haulotte**   
GROUP

More than lifting





# HA16 RTJ PRO



## ROUGH TERRAIN ARTICULATING BOOMS

### TECHNICAL DATA

### HA16 RTJ PRO

4WD/4WS

Front oscillating axle

	Metric	US
Working height	16 m	51 ft 11 in
Platform height	14 m	45 ft 11 in
Horizontal outreach	8.3 m	27 ft 3 in
Up and over clearance	7.65 m	25 ft 1 in
Lift capacity	230 kg (2 persons)	500 lbs (2 pers.)
<b>F</b> x <b>G</b> Platform size	2.44 m x 0.91 m	8 ft x 3 ft
<b>A</b> Length - stowed	6.87 m	22 ft 6 in
<b>H</b> Transport length (jib tucked under)	5.10 m	16 ft 9 in
<b>B</b> Width	2.44 m	8 ft
<b>C</b> Height - stowed	2.3 m	7 ft 7 in
<b>I</b> Transport height	2.51 m	8 ft 3 in
Jib length	1.2 m	3 ft 11 in
Vertical jib rotation	140° (-80°/+60°)	
Platform rotation	165° (-75°/+90°)	
Turntable rotation	360° continuous	
<b>D</b> Wheelbase	2.1 m	6 ft 11 in
<b>E</b> Ground clearance	38 cm	15 in
Tilt	5°	
Drive speed	Up to 5.6 km/h	Up to 3.5 mph
Gradeability	40 %	
Turning radius - outside	3.75 m	12 ft 4 in
Tires cured on solid Rough Terrain	14x17.5	
Power source	Kubota 26 kW - 35 hp	
Hydraulic system capacity	76 l	20.1 gal
Fuel tank capacity	62 l	16.4 gal
Weight	6650 kg	14,663 lbs

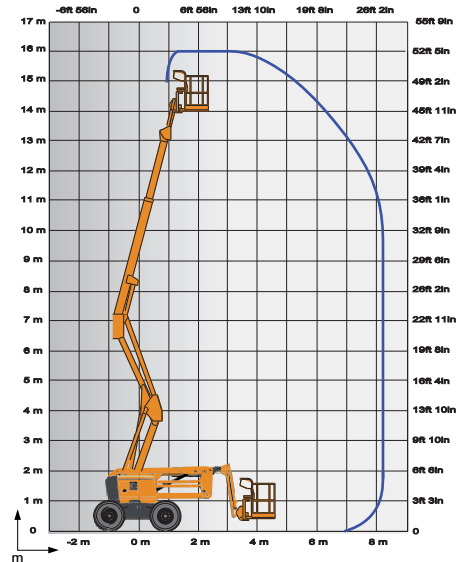

### STANDARD EQUIPMENT

- 4 wheel drive
- 4 wheel steer
- Front oscillating axle increases stability on uneven ground
- Permanent limited slip differential
- 230 kg / 500 lbs (2 persons) load capacity
- 4 simultaneous movements for maximum productivity
- Safe to use in winds up to 60 km/h / 37 mph
- Rotating beacon
- Modular large basket 2.44 m x 0.91 m / 8 ft x 3 ft quick and easy to repair
- Lateral swing door entry gate
- Upper control box cover
- Tool tray
- Hydraulic generator Dynaset 6.5Kw
- AC power to platform (110/230V)
- Self-diagnosis tool on lower control box
- Swing out engine tray for ease of maintenance
- Hour meter
- Low fuel level indicator (upper & lower control boxes)
- Engine pre-heater with light indicator
- Sound and light alarm for tilt and load
- 12 V battery / electrical control system
- Electric pump system and emergency descent
- Alarm package

### OPTIONS AND ACCESSORIES

- Air-line to platform 6.5 mm inner diameter
- 70W working light
- Power to platform (Female plug in the basket with or without circuit-breaker 30mA)
- Flashing light
- Cold weather kit : -10°C / -25°C
- Hot weather kit : hydraulic oil cooler + hydraulic oil
- Biodegradable hydraulic oil
- Large cured on solid Rough terrain tires 385/65
- Non-marking tires 14x17.5
- Catalytic exhaust for diesel engine
- Spark arrestor and electric one-way valve
- Battery cut-off
- Haulotte Activ'Shield© Bar : Exclusive secondary guarding device

